

MB19 PNEUMATIC PRESS

Die Quip's MB19 pneumatic number stamp press is the perfect solution for large quantity die marking. Using permanent number stamps to prevent loss of identification in the plant the MB19 is quick and easy to use. Just place the die under the stamp head and press the foot peddle.

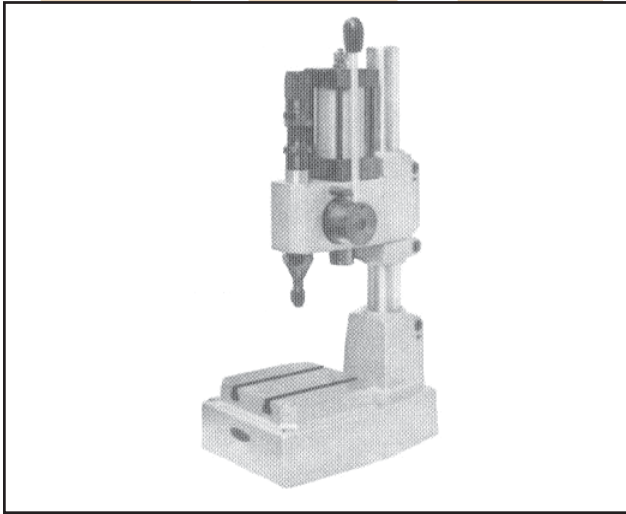

Specifications

Height	14.8" (375mm)
Weight	35lbs (16kg)
Throat	6 5/8" (170mm)
Table	4 1/2" (110mm) Square
Air pressure	40-50 PSI (2.78-3.47 bar)
Die Capacity	1-4" (25-100mm)
Pressure	.75 Ton (700kg)

Stamping Heads & Numbers

Our quality engineered marking tools are made with deep chisel-like characters to produce a clear, distinctive impression on the die. Top quality alloy tool steels and unique hardening process assure you superior stamp life. Stamps available in 1/16 (1.6mm), 3/32 (2.4mm), 5/32 (4mm), 3/16 (4.8mm) and 1/4" (6.4mm) heights.



Manual Stamping Head

Manual stamp heads are an inexpensive method to set the number to be marked on the die. The quick locking lever makes changing numbers fast and easy. The stamp height and number of characters needs to be specified when ordering.

Rotary Stamping Head

The rotary stamping head is the quickest method to change characters when marking dies. Just dial the number that you want and start stamping. The stamp height and number of characters needs to be specified when ordering.



DIE QUIP CORP.

5360 Enterprise Blvd.
Bethel Park, PA 15102 USA
412/833-1662
412/835-6474 FAX
www.DIEQUIP.com
email - DIEQUIP@DIEQUIP.com